



## ***MANUAL for INSTALLATION, RUNNING and MAINTENANCE***

### ***Patio-heaters:***



***models KALIENTE E/M and SOLFLAME E/M***



***models KALOR M and SOLEIL M  
(manual start-up)***

SIABS S.r.l. – ITALY  
via Del Lavoro, 7  
20010 – Casorezzo (MILAN)

Phone +39 02 90384081  
Fax +39 02 9029538

E-mail [commerciale@siabs.it](mailto:commerciale@siabs.it)  
Web page [www.siabs.com](http://www.siabs.com)

## **CONTENT**

<b>General instruction</b>	<b>3 and 4</b>
<b>For Your safety</b>	<b>5</b>
<b>Warranty terms</b>	<b>5</b>
<b>CE declaration of conformity</b>	<b>5</b>
<b>Labels</b>	<b>6</b>
. plate with technical data	6
. packing label	6
<b>Technical data</b>	<b>7 and 8</b>
. patio-heaters <b>KALIENTE</b> M & E	7
. patio-heaters <b>KALOR</b> M & E	8
<b>Dimensions</b>	<b>9</b>
<b>MINIMUM distance of installation</b>	<b>10</b>
<b>Installation</b>	<b>11 and 12</b>
. room ventilation	11
. notices	11
. description of patio-heaters	12
. get ready to working – suggestions	12
<b>Put in operation and First Start-up</b>	<b>13 – 17</b>
. position of heater, handling and gas bottle positioning	13 and 14
. suggested gas bottle	14
. start-up	15 – 17
<b>Safety devices</b>	<b>18</b>
<b>Maintenance</b>	<b>19 and 20</b>
. ordinary maintenance	19
. replacement of the glass pipe, patio-heater <b>KALIENTE</b>	19
. nozzle replacement	20
<b>Trouble shooting</b>	<b>21 – 23</b>
. <b>KALIENTE</b> Manual	21
. <b>KALIENTE</b> Electronic	22
. <b>KALOR</b> Manual and Electronic	23
<b>Suggested spare-parts list</b>	<b>24</b>
<b>Service sheet</b>	<b>25</b>
<b>CE certificate</b>	<b>26</b>
<b>Decommissioning and disposal (norms for user)</b>	<b>27</b>

### **NOTE**

- **KALIENTE** (with glass tube and flame)
- **KALOR** (with burner in metallic fiber)

## GENERAL INSTRUCTIONS for INSTALLER, USER and MAINTENANCE PERSONNEL

**Thank you for your preference and trust granted!** SIABS is pleased to have You among his Customers; our appliances are designed and manufactured to the most modern and rational processing systems and we do think you will appreciate the pleasant comfort and their use will be fully satisfactory.

To keep appliances perfectly working and safe, time passing, **WE INVITE YOU to READ and FOLLOW the instructions** of this handbook and **commit all installation and maintenance (ordinary and extraordinary) operations only to skilled personnel**, with specific technical skills in the field of components of heating, preferably to SIABS authorized Service Centre.

### ***For the INSTALLER:***

- **read carefully the warnings** in the manual **before performing any operation** as they provide important information concerning the safety of installation, use and the necessary maintenance operations to be performed
- this manual is integral and essential part of the product and **must be delivered to the user; retain it carefully for further consultations**
- **in case of non-compliance with the following instructions, the warranty covering the product(s) will be null and void**
- **BEFORE THE INSTALLATION**, verify that local gas distribution (type of gas and pressure) and appliance settings are compatible
- appliance must be **installed only in premises with adequate ventilation**
- installation should be done in **accordance with the Regulations in force** in the country of destination, to the state of art, following instructions by the Manufacturer
- the appliance must be used solely for the use for which it was designed: any other use is considered improper and therefore dangerous
- **incorrect installation can cause damage** to people, animals and things; the Manufacturer doesn't accept any contractual and extra-contractual liability in tort and contract for damages caused by errors in installation and use
- we suggest to make use only of SIABS device for transport / handling (optional), named "kit for transport"
- **transport / handling MUST take place only when patio-heater is cold** (safety of people and protection of its components), **TAKING CARE TO SECURE THE GLASS TUBE (model KALIENTE) WITH CLAMPS**
- use only original accessories and modification kits
- after you have removed all items from packing box, **make sure that all components have been included and their integrity**, in case of doubt not use the appliance and contact the Manufacturer; elements of packaging are potentially dangerous: therefore should not be left within the reach of children and must be disposed according to regulations in force
- before any cleaning or maintenance operation, **wait until the appliance is cold, disconnect it from the electricity supply and bring the fuel shut-off valve in the closed position**
- **FOR NO REASON** you can change the working parameters set in the factory (nozzle or air intake)

**For the USER and OWNER of the patio-heaters:**

- this manual is integral and essential part of the product and **must be delivered to the user; retain it carefully for further consultations**
- **in case of non-compliance with the following instructions, the warranty covering the product(s) will be null and void**
- the appliance must be used solely for the use for which it was designed: any other use is considered improper and therefore dangerous
- **incorrect installation can cause damage** to people, animals and things; the Manufacturer doesn't accept any contractual and extra-contractual liability in tort and contract for damages caused by errors in installation and use
- we suggest to make use only of SIABS device for transport / handling (optional), named "kit for transport"
- **AFTER EACH USE**, turn off the tap on the gas bottle
- **transport / handling MUST take place only when patio-heater is cold** (safety of people and protection of its components), **TAKING CARE TO SECURE THE GLASS TUBE (model KALIENTE) WITH CLAMPS**
- **DO NOT LEAVE CHILDREN UNATTENDED close to the patio-heater:** some components are warm
- we recommend to replace the gas bottle in a well ventilated area, far from heat sources
- use only original accessories and modification kits
- every time the gas bottle is replaced, **check that gasket of gas regulator is in correct position** and works as requested
- you should check periodically the flexible gas pipe to check for any anomalies and **replace it according to the expiring date stamped on it**
- before any cleaning or maintenance operation, **wait until the appliance is cold, disconnect it from the electricity supply and bring the fuel shut-off valve in the closed position**
- in case of failure and/or malfunction of the appliance, turn it off refraining from any attempt to repair or direct intervention; **contact SIABS authorized Service Centre**
- contact the producer in case of change of gas nozzle; i.e. from LPG to natural gas (or vice versa)
- when you decide to stop using the appliance, for **DISPOSAL or RESALE**, you will have to render harmless all parties which can be a source of potential danger; **the technical manual is integral and essential part of the product: it must be preserved and accompany the appliance in case of property change, so that it can be consulted by the new user and / or maintenance staff**

***N.B. – BATTERIES to be used***

***Patio-heaters with ELECTRONIC start-up***

- **for remote control** of patio-heaters KALIENTE E & SOLFLAME E = model **AAA**
- **for gas group** of patio-heaters KALIENTE E & SOLFLAME E = model type **Torch**

***Patio-heaters with MANUAL start-up***

- **for gas group** of patio-heaters KALIENTE M & SOLEIL M = model **AA**  
**note – they are inside the piezo starter**

## FOR YOUR SAFETY



**In case of gas smell:** DO NOT operate the heating plant, vent the ambient, DO NOT start apparatus or electric switches; contact the installer and gas supply company and follow scrupulously their instruction

**IMPORTANT:** appliances **MUST NOT be used in domestic environments.** This appliance will be devoted only to the use for which it was expressly provided, **all other uses will be considered improper and therefore dangerous.**

**IMPORTANT:** appliances **MUST NOT be used in ambient with flammable materials, liquids or vapours:** non-compliance with these requirements may be cause of death, injury to persons or damage to things.

## Warranty

SIABS guarantees its products, whether installed by authorized personnel, for a period of 24 months from the invoice date. The warranty does not cover the components supplied by third parties, these are subject to the conditions of the original warranty.

The guarantee is only the free supply on Ex-Works basis, of parts with manufacturing or workmanship defects.

The guarantee does not cover problems due to carelessness, incorrect setting, misuse of the appliance or fortuitous accidents, and not dependent on imperfection processing or defective materials, and those due to dismantling or changes without prior authorization from SIABS.

The correct functioning of the appliances depends on a proper installation and start-up. Failure to comply with these rules immediately involves the decay of the guarantee, and therefore of responsibility by the manufacturer.

## ***CE declaration of CONFORMITY***

**SIABS S.r.l.** patio-heaters, models:

- ***KALIENTE M – SOLFLAME M***
- ***KALIENTE E – SOLFLAME E***
- ***KALOR M – SOLEIL M***

comply with communitarian directives referring to gas heaters for out-door installation  
***EN 14543:2005+A1:2007.***

***N.B. – all components of SIABS patio-heaters are CE certificated  
PLATE LABEL***



On each unit you will find a plate with technical data – **do not remove** – placed inside the gas bottle compartment, on the burner cover.

### Apparatus type A1,

 Phone +39-02-90384081 - ITALY www.siabs.com		This appliance must be installed in accordance with the rules in force. It shall be used in a spaces with at least 25 % open surface, in accordance with the requirements of EN 14543:2005 A1:2007. Consult the instruction before installation and use of this appliance.		
Model	KALIENTE m	PIN code	0694CN6054	 0694
Version	MANUAL	Country of destination	GB	
Gas category	II 2H3P	Year of production	2013	
 After USE, close the gas bottle valve or regulator				
HEATER CATEGORY	: A1	Gas type	G31	
Tension	- Volt	Nominal heat input MAX	10.2	kW
Frequency	- Hz	Nominal heat input MIN	8.0	kW
Absorbed power	- Watt	Gas consumption MAX / MIN	0.79 - 0.60	kg/h
Protection rate	IP20	MAX feeding pressure	37.0	mbar
Nozzle diameter	1.60 mm			
NOx category	4			
<b>DO NOT USE IN DOMESTIC AMBIENT</b>				

**Plate label** (example: patio-heater KALIENTE Electronic, gas type G31 propane)

Essential features of the appliance are given on the packing label, outside on the packing box.

dal 1952 <b>SIABS</b> <sup>®</sup> bruciatori & calore radiante		 0694
<a href="http://www.siabs.com">www.siabs.com</a> -  +39_02_90384081		
Gas category	II 2H3P	<b>GAS TYPE</b> G31 - 37 mbar
Country of destination	United Kingdom	
<b>Radiant heater : KALIENTE</b>		
<b>Version : manual</b>		
<b>Note : BLACK color panels</b>		
 This appliance must be installed in accordance with the rules in force. It shall be used in a spaces with at least 25 % open surface, in accordance with the requirements of EN 14543:2005 A1:2007. Consult the instruction before installation and use of this appliance.		

## TECHNICAL DATA, *patio-heaters KALIENTE E / M – SOLFLAME E/M*

Country	Category	Gas	Pressure	Gas	Pressure
AT	II 2H3B/P	G20	20 mbar	G30 / G31	50 mbar
BE	II 2E+,I3+	G20 / G25	20 / 25 mbar	G30 / G31	28-30 / 37 mbar
DE	II 2ELL3B/P	G20 / G25	20 mbar	G30 / G31	50 mbar
DK, SE, FI	II 2H3B/P	G20	20 mbar	G30 / G31	30 mbar
ES, GB, GR	II 2H3P	G20	20 mbar	G31	37 mbar
FR	II 2E+,I3+	G20 / G25	20 / 25 mbar	G30 / G31	28-30 / 37 mbar
IE, PT	II 2H3P	G20	20 mbar	G31	37 mbar
IS	I 3P			G31	30 mbar
IT	II 2H3+	G20	20 mbar	G30 / G31	28-30 / 37 mbar
LU	II 2E3P	G20	20 mbar	G31	37 mbar
NL	I 2L3B/P	G20	25 mbar	G30 / G31	37 mbar
NO	II 2H3B/P	G20	20 mbar	G30 / G31	50 mbar
CY, MT	I 3B/P			G30 / G31	30 mbar
EE, LT, LV	II 2H3B/P	G20	20 mbar	G30 / G31	30 mbar
EE, LT, LV	II 2H3P	G20	20 mbar	G31	37 mbar
CZ	II 2H3B/P	G20	20 mbar	G30 / G31	30 mbar
SK, SI, BG	II 2H3B/P	G20	20 mbar	G30 / G31	30 mbar
SK, SI	II 2H3P	G20	20 mbar	G31	37 mbar
RO, C*	II 2H3+	G20 / G25	20 / 25 mbar	G30 / G31	28-30 / 37 mbar
HU	II 2H3B/P	G20	25 mbar	G30 / G31	30 mbar
PL	II 2E3B/P	G20	20 mbar	G30 / G31	37 mbar
PL	II 2E3P	G20	20 mbar	G31	37 mbar
CH	II 2H3+	G20	20 mbar	G30 / G31	28-30 / 37 mbar
HR	II 2H3B/P	G20	20 mbar	G30 / G31	30 mbar
TR	II 2H3B/P	G20	20 mbar	G30 / G31	30 mbar

- **Gas G30-G31 at 28/30/37 mbar**

Heating power MAX 10.2 kW  
 Power MIN 8.0 kW

gas nozzle 1.6 mm  
 consumption 0.79 kg/h  
 consumption 0.60 kg/h

Category A1

- **Gas G30-G31 at 50 mbar**

Heating power MAX 10.2 kW  
 Power MIN 8.0 kW

gas nozzle 1.6 mm  
 consumption 0.79 kg/h  
 consumption 0.60 kg/h

Category A1

**N.B. – 1.6mm gas diaphragm is compulsory**

- **Gas G20 at 20 mbar**

Heating power MAX 10.2 kW  
 Power MIN 6.0 kW

gas nozzle 2.5 mm  
 consumption 0.98 m<sup>3</sup>/h  
 consumption 0.59 m<sup>3</sup>/h

Category A1

- **Gas G25 at 25 mbar**

Heating power MAX 10.2 kW  
 Power MIN 6.0 kW

gas nozzle 2.5 mm  
 consumption 1.03 m<sup>3</sup>/h  
 consumption 0.60 m<sup>3</sup>/h

Category A1

- **Gas G20 at 25 mbar**

Heating power MAX 10.2 kW  
 Power MIN 6.0 kW

gas nozzle 2.3 mm  
 consumption 0.98 m<sup>3</sup>/h  
 consumption 0.62 m<sup>3</sup>/h

Category A1

- **NOx class = 4**

- **Weight = approx. 30 kg**

## **TECHNICAL DATA, patio-heaters KALOR M – SOLEIL M**

Country	Category	Gas	Pressure	Gas	Pressure
AT	II 2H3B/P	G20	20 mbar	G30 / G31	50 mbar
BE	II 2E+,I3+	G20 / G25	20 / 25 mbar	G30 / G31	28-30 / 37 mbar
DE	II 2ELL3B/P	G20 / G25	20 mbar	G30 / G31	50 mbar
DK, SE, FI	II 2H3B/P	G20	20 mbar	G30 / G31	30 mbar
ES, GB, GR	II 2H3P	G20	20 mbar	G31	37 mbar
FR	II 2E+,I3+	G20 / G25	20 / 25 mbar	G30 / G31	28-30 / 37 mbar
IE, PT	II 2H3P	G20	20 mbar	G31	37 mbar
IS	I 3P			G31	30 mbar
IT	II 2H3+	G20	20 mbar	G30 / G31	28-30 / 37 mbar
LU	II 2E3P	G20	20 mbar	G31	37 mbar
NL	I 2L3B/P	G20	25 mbar	G30 / G31	37 mbar
NO	II 2H3B/P	G20	20 mbar	G30 / G31	50 mbar
CY, MT	I 3B/P			G30 / G31	30 mbar
EE, LT, LV	II 2H3B/P	G20	20 mbar	G30 / G31	30 mbar
EE, LT, LV	II 2H3P	G20	20 mbar	G31	37 mbar
CZ	II 2H3B/P	G20	20 mbar	G30 / G31	30 mbar
SK, SI, BG	II 2H3B/P	G20	20 mbar	G30 / G31	30 mbar
SK, SI	II 2H3P	G20	20 mbar	G31	37 mbar
RO, C*	II 2H3+	G20 / G25	20 / 25 mbar	G30 / G31	28-30 / 37 mbar
HU	II 2H3B/P	G20	25 mbar	G30 / G31	30 mbar
PL	II 2E3B/P	G20	20 mbar	G30 / G31	37 mbar
PL	II 2E3P	G20	20 mbar	G31	37 mbar
CH	II 2H3+	G20	20 mbar	G30 / G31	28-30 / 37 mbar
HR	II 2H3B/P	G20	20 mbar	G30 / G31	30 mbar
TR	II 2H3B/P	G20	20 mbar	G30 / G31	30 mbar

- **Gas G30-G31 at 28/30/37 mbar**

Heating power MAX 10.2 kW  
 Power MIN 8.0 kW

gas nozzle 1.5 mm  
 consumption 0.79 kg/h  
 consumption 0.60 kg/h

Category A1

- **Gas G30-G31 at 50 mbar**

Heating power MAX 10.2 kW  
 Power MIN 8.0 kW

gas nozzle 1.5 mm  
 consumption 0.79 kg/h  
 consumption 0.60 kg/h

Category A1

- **Gas G20 at 20 mbar**

Heating power MAX 10.5 kW  
 Power MIN 6.5 kW

gas nozzle 2.6 mm  
 consumption 0.995 m<sup>3</sup>/h  
 consumption 0.61 m<sup>3</sup>//h

Category A1

- **Gas G25 at 25 mbar**

Heating power MAX 10.5 kW  
 Power MIN 6.5 kW

gas nozzle 2.6 mm  
 consumption 1.075 m<sup>3</sup>/h  
 consumption 0.65 m<sup>3</sup>/h

Category A1

- **Gas G20 at 25 mbar**

Heating power MAX 10.5 kW  
 Power MIN 6.5 kW

gas nozzle 2.3 mm  
 consumption 0.92 m<sup>3</sup>/h  
 consumption 0.62 m<sup>3</sup>//h

Category A1

- **NOx class = 4**

- **Weight = approx. 30 kg**



**OVERALL DIMENSIONS,  
patio-heaters  
KALIENTE & KALOR & SOLFLAME & SOLEIL**

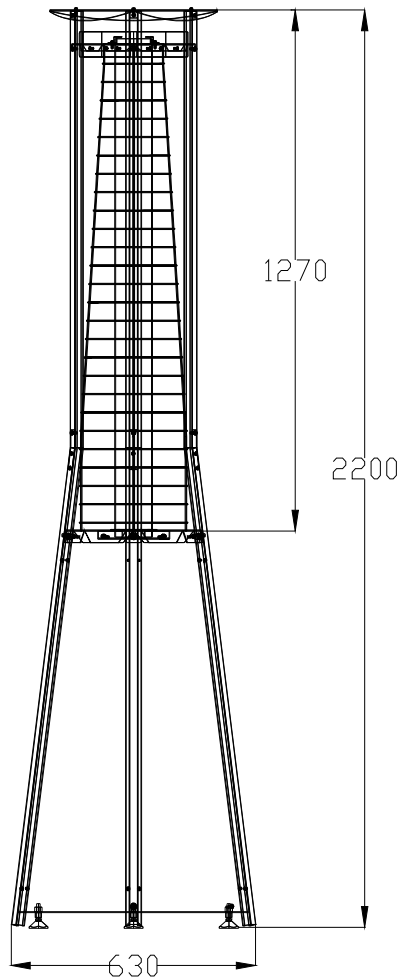

NOTE – we recommend to make use of the 4 adjustable feet, to ensure always optimal vertical position, and avoid floor / surface damage.

***MINIMUM distance of installation,***

*patio-heaters*  
**KALIENTE & KALOR & SOLFLAME & SOLEIL**

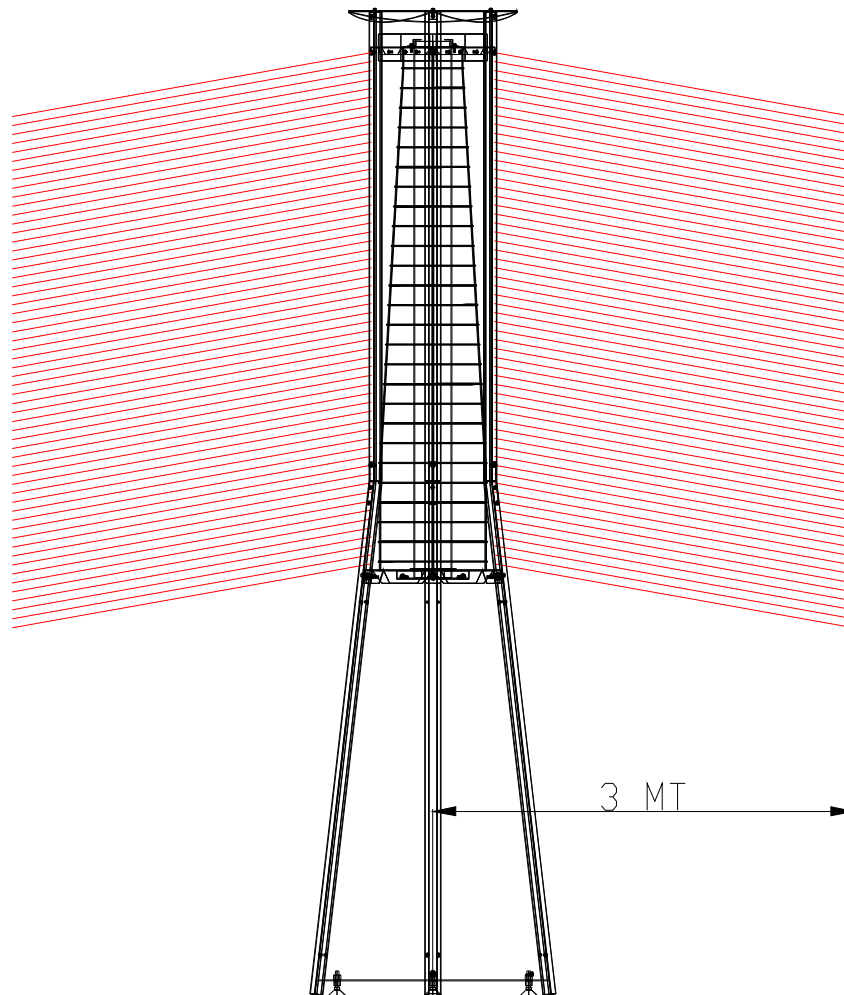

By minimum distance of installation we mean the distance to be kept between the patio-heater and any component potentially flammable. **We recommend to keep at least 0.5 mt between the cover / top of the patio-heaters and the ceiling.** The best comfort is at a distance of approx. 3 mt.

# **INSTALLATION, patio-heaters KALIENTE & KALOR & SOLFLAME & SOLEIL**

## **ROOM VENTILATION**



**Patio-heaters must be installed in spaces with at least 25 % open surface**

## **NOTICES**

SIABS patio-heater is a product with modern aesthetics, designed to give comfort in all spaces which need complete or partial heating.

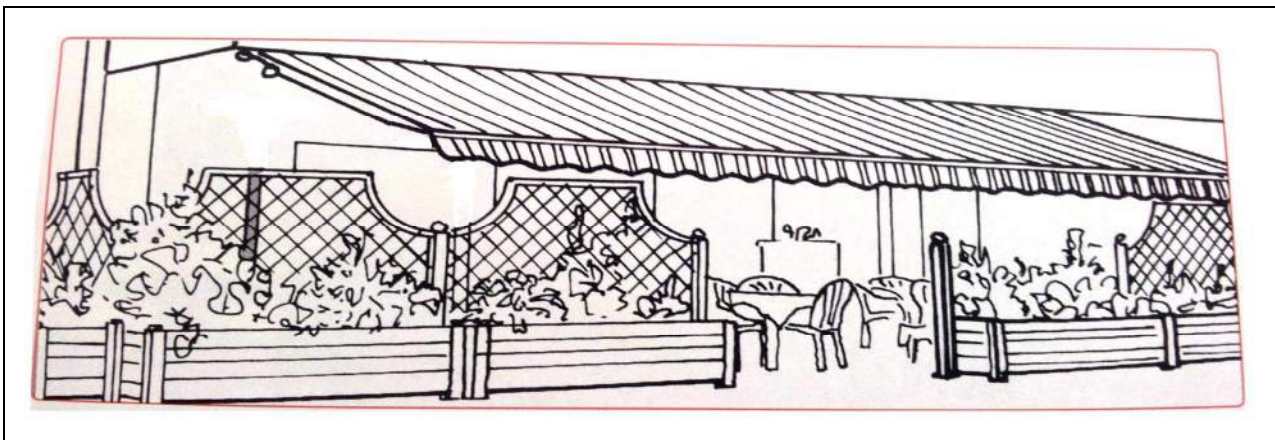

SIABS patio-heaters must be installed **in partly protected areas**: it is not designed to be subject to direct action of atmospheric agents (snow, raining, hail). **We strongly advise against the installation in direct contact with atmospheric agents.**

## DESCRIPTION of PATIO-HEATERS

SIABS patio-heaters are designed and built with attention to detail, a lot of attention to reliability and giving importance to design: they have a reflecting steel structure, panels of bottle compartment can be customized with different colors, safety grids on all sides, high efficiency and long life, burner made in metallic fiber, heating element with flame and safety glass (model **KALIENTE**), adjustable feet.

Installation is easy and in no time the heaters are ready for operation: you just have to place and connect the gas cylinder after removing the front panel (with slot).

All heaters are controlled and calibrated to the correct pressure values (depending on the type of gas and the country of destination), and then tested in the company by SIABS personal. On each heater you will find a technical data plate (see page 6 of this manual), according to norms, to which the installer has to refer for any future action.

SIABS patio-heaters are certified and approved for use with natural gas or LPG; the burner has been subjected to strict tests (with gas operating limits) in the laboratories of our approval authority KIWA Gastec – Italy.

## GET READY TO WORKING – SUGGESTIONS

Below you will find **IMPORTANT** suggestions:

- SIABS patio-heaters can be supplied:
  - **fully pre-assembled:** you have only to provide the gas bottle and the pressure reduction kit (flexible pipe + pressure reducer, different from country to country)
  - **to be assembled on site:** burner is fully mounted and tested in our factory, all other components are easy to be assembled, following specific instruction
- pay particular attention **during unloading and all handling operations** of the heater due to the fragility of the glass tube (model **KALIENTE**)
- open the carton in a horizontal position on a stable surface or on the floor, then lifting the product with the help of a second person (weight approx. 45 kg)
- **cut the clamp that fixes the glass tube** (model **KALIENTE**) before start-up
- verify that the feed pipe and the gas coupling installed are in compliance with the regulations in force in the country of use
- in case of gas smell while patio-heater is running, **switch off it immediately and verify any gas leaks before using it again:** you can use soapy water or equivalent
- when replacing the LPG gas bottle, you can use soapy water or equivalent to check connections and fittings for leaks
- **IMPORTANT:** at the first ignition is likely to happen a delay in turning the pilot flame; the situation is normal, and due to the fact that the circuit has gas inside air to be disposed of; the inconvenience will disappear with two or three ignitions. To avoid any darting flames, let about 2 minutes between each ignition procedure and the next. This situation could be repeated when replacing a gas bottle: proceed as above.

- **transport / handling MUST take place only when patio-heater is cold** (safety of people and protection of its components), **TAKING CARE TO SECURE THE GLASS TUBE (model KALIENTE) WITH CLAMPS**

## ***PUT in OPERATION and FIRST START-UP***

### **POSITIONING of HEATER, HANDLING and GAS BOTTLE POSITIONING**

**POSITIONING of HEATER:** with heater in vertical position, set the adjustable feet (Picture 1) placed in the lower part of gas bottle compartment, to avoid the swing of the unit.



Picture 1

**HANDLING:** for all movements of the patio-heater, for secure and easier handling we recommend to use only SIABS device for transport / handling (optional), named "kit for transport", fixing it to the lower part of gas bottle compartment (Picture 2), with n. 4 M8 bolts, included in the supplied. Secure with M8 bolts the "kit for transport" on the base plate supporting the gas bottle, tilt the heater toward you as in the picture (Picture 3), resting a foot on the "kit of transport." Weight of unit is approx. 40 kg.



Picture 2

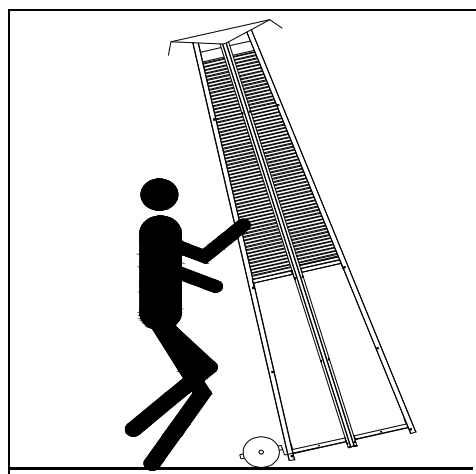

Picture 3

**OPENING of GAS BOTTLE COMPARTMENT:** using a cross screwdriver, remove the front cover (the one with the slot, Picture 4) by unscrewing top and bottom bolted connections (Picture 5).



Picture 4

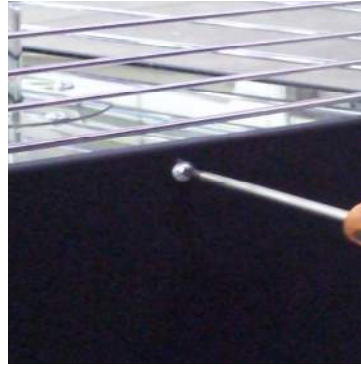

Picture 5

**GAS BOTTLE POSITIONING:** place the gas bottle inside the compartment, and secure it with the chain (Picture 6).



Picture 6



Picture 6

Then, connect the pressure reducer (supplied) on top of gas bottle, using a M25 spanner (Picture 7). Tighten with a fixed spanner the fitting of the pressure reducer on top of gas bottle and slowly open the tap of the gas bottle (Picture 8).



Picture 7



Picture 8



**check with soapy water or equivalent material losses on the connection**

### **LPG suggested GAS BOTTLE**

LPG is delivered to users in portable containers (bottles) to be replaced with new at the time of exhaustion. Gas bottles respond to a series of rules issued by the bodies that determine the materials and testing. SIABS patio-heaters are suitable for use of 10 – 15 kg LPG bottles.

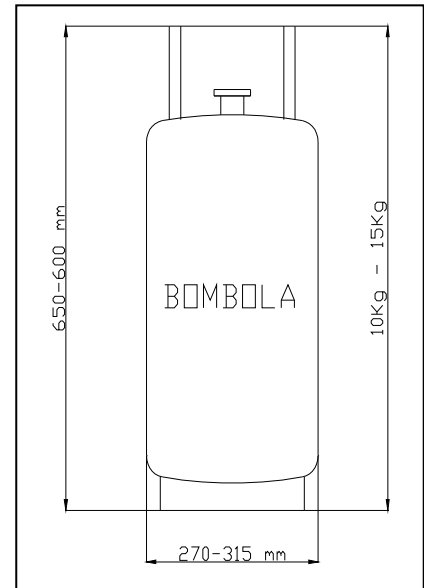

## START-UP

Carried out the above steps successfully, you can turn on the power to the heater.

**ELECTRONIC VERSION patio-heater model KALIENTE E/SOLFLAME E:** press the **POWER button on the remote control**, after a few seconds the ignition device (pilot), by the detection electrode, will give positive input for total opening of the gas valve, and then turning on the heater takes place; one remote can manage more heaters (on, off, level of power).

**To switch off**, press the **POWER button again** (Picture 9) on the remote control.

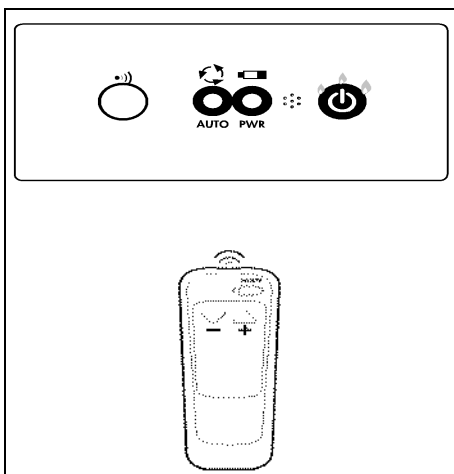

Picture 9

**In case of REMOTE CONTROL FAULT:** patio-heaters in the electronic version can run even if the remote control has trouble; work directly from the control unit placed inside the gas bottle compartment, as in the picture

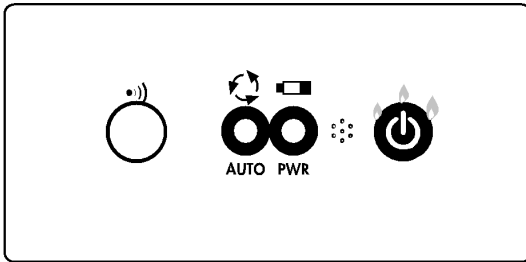

**START-UP BUTTON**

PUSH once	- MAX FLAME
PUSH 2 times	- MED FLAME
PUSH 3 times	- MIN FLAME
PUSH 4 times	- OFF

Picture 10

**N.B. – BATTERIES for Patio-heaters with ELECTRONIC start-up**

- for remote control of patio-heaters KALIENTE E & SOLFLAME E = model **AAA**
- for gas group of patio-heaters KALIENTE E & SOLFLAME E = model type **Torch**

**MANUAL VERSION patio-heater model KALIENTE M / SOLFLAME M:**

- press and turn counter-clockwise about 15 ° the gas valve / knob
- holding the knob in position, **press the red start-up button** located under the knob, **until ignition of the pilot device** (Picture 11)
- with pilot flame on, **leave the ignition red button while pushing and keeping in place and knob for 10 ÷ 20 seconds**
- **leave the knob** and verify that the pilot device stays on, repeat the operation if the pilot device goes out

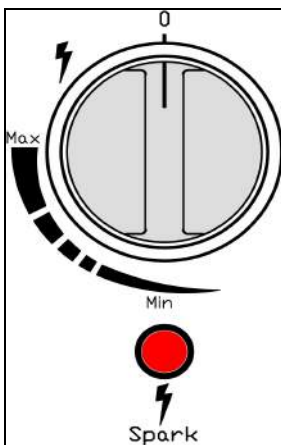

Picture 11

**NOTE – to switch off**, turn the knob to **position 0** = ZERO (Picture 11).

**MANUAL VERSION patio-heater model KALOR M / SOLEIL M**

- press and turn counter-clockwise the gas valve / knob, **till maximum position**
- holding the knob in position, **press the red start-up button** located under the knob, **until start-up of the burner**
- with burner running, **leave the ignition red button while pushing and keeping in place and knob for 10 ÷ 20 seconds**
- **leave the knob** and verify that burner keeps working; repeat the operation in case of burner stop

**NOTE – to switch off**, turn the knob to **position 0** = ZERO (Picture 11).



**N.B. – BATTERIES for Patio-heaters with MANUAL start-up**

- for gas group of patio-heaters **KALIENTE-SOLFLAME M** & **KALOR-SOLEIL M** model **AA** =  
**note – they are inside the piezo starter**

**POSSIBILITY of ADJUST POWER:** all SIABS patio-heaters, offer the possibility to adjust the heating power (max-min-med) reducing it by approx. 20%, in case you want to enjoy a different level of comfort or fit it to different external temperatures.

**MANUAL version,** with pilot device on, turn the knob towards MIN or MAX as on the plate (Picture 11) until you get the require comfort level.

**ELECTRONIC version with remote control,** the intensity can be adjusted using the buttons (- and +) on the remote control, placed under the POWER button (Picture 12).

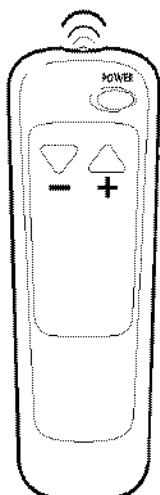

<b>BUTTON</b>	<b>+</b>	
PUSH 3 times		– MAX FLAME
PUSH 2 times		– MED FLAME
PUSH once		– MIN FLAME
<b>BUTTON</b>	<b>-</b>	
PUSH 3 times		– MIN FLAME
PUSH 2 times		– MED FLAME
PUSH once		– MAX FLAME

Picture 12

## **SAFETY DEVICES on PATIO-HEATERS**

**N.B.** – SIABS patio-heaters are delivered ready for operation, already set according to the type of gas and the country of destination, and equipped with a pressure reducer: **does not require additional settings, or other accessories; shall not be permitted any change in burner pressure running: guarantee will not be valid anymore.** We are at your disposal for any questions or requests.

If the pilot flame keeps going out, see system faults (pages 19 to 22 – TROUBLE SHOOTING) and follow the instructions; if for any reason the heater turns off, the thermocouple placed on the pilot ensures safety: thermocouple acts quickly on the valve to avoid any leakage of gas.

The thermocouple placed on the ignition pilot detects the flame, and locks the gas circuit if the heater turns off due to lack of gas or accidentally; plus, there is also a mechanical device called ANTI TILT (anti rollover), that automatically stops gas leakage by turning off the burner, when the heater is tilted or occurs an accidental rollover. In this type of heaters that safety is a key and expressly required by law.

To turn on the heater again, we must repeat the normal start-up procedure (see page 15 - START-UP). For cases of accidental switching off or empty gas bottle, repeat the ignition procedure, letting few minutes from the previous year.

**N.B.** – **avoid consecutive ignition attempts:** if the heater has problems in this regard, check that all the operations required above are fulfilled and executed in a positive way; then, in case of negative result, contact the manufacturer.

## MAINTENANCE

A correct use, plus proper and regular maintenance are essential to ensure a better performance and greater durability.



**Before making any maintenance, make sure that both the gas and the power supply have been excluded, and that the apparatus is cold.** For all routine and / or extraordinary maintenance, contact only professionally qualified staff, or rather a Technical Assistance Centre authorized by SIABS

### Ordinary maintenance

**At least once a year**, before the season of use, it is strongly advisable to:

- replace gas tube, in case it is damaged or validity expired
- replace the worn parts, which are part of the patio-heaters
- replace of remote control batteries or piezo starter
- replace of batteries of gas group (electronic version)
- cleaning of patio-heaters with a wet soft cloth, **not flammable or corrosive solvents**

Depending on the quality of gas used, it **may cause blackening of the tubular glass** (model KALIENTE E & M) due to the components added to the mixture of propane gas and dirt in general; **for cleaning the inside of the glass tube, it can be used a wet soft cloth**, restoring the starting transparency.

### Replacement of the glass pipe, patio-heater KALIENTE/SOLFLAME

If it should become necessary to replace the glass tube (blackening important after a few years, or accidental breakage), proceed as follows:

- **wait until the patio-heater is cold, in all its parts**
  - remove upper cap (4 hex screws 8mm self-tapping)
  - remove 1 of the side nets (4 or 6 star screws with nut passers-7mm)
  - remove the upper glass support, \_I\_ shaped, (1 star screw) or the white fibre gasket
  - remove the broken glass tube – PAY ATTENTION
- remove 1 side panel, and hold the burner group by hand**
- remove (4 star screws) the plate supporting the glass pipe, stainless steel made
  - remove the lower guide (white fibre gasket), if any

then:

- position the lower guide (white fibre gasket)
- mount (4 star screws) the plate supporting the glass pipe, inox made
- position the upper guide (white fibre gasket)
- place the new glass tube
- re-install the side net
- re-install upper cap
- mount side panel

**Transport / handling MUST take place only when patio-heater is cold** (safety of people and protection of its components), **TAKING CARE TO SECURE THE GLASS TUBE (model KALIENTE - SOLFLAME) WITH CLAMPS**

### Nozzle replacement

In case there is the need to change the type of gas, different from that the heater has been tested, **it is necessary to require SIABS the correct conversion kit specifying the appliance model, serial number** (inside the gas bottle compartment, Picture 13) **and the new gas type**. The operation must be performed by qualified personnel, preferably SIABS service center, in accordance with the regulations in force.



Picture 13

**IMPORTANT:** if you change the gas nozzle to change type of gas (e.g. from LPG to natural gas) **it is COMPULSORY to change the PRESSURE STABILIZER – only for manual start-up version – and to change the plate label with technical data** and place one with the new data, then repeat the checks at pages 13 and 14 "PUT in OPERATION and FIRST START-UP"

**Patio-heater KALIENTE-SOLFLAME:** to replace the gas nozzle remove two panels of the gas bottle compartment, remove the cover plate of the burner unit (Picture 14) and unscrew the brass gas nozzle with M13 key (Picture 15). Place the new nozzle and tighten with the spanner, fix the cover plate of the burner.

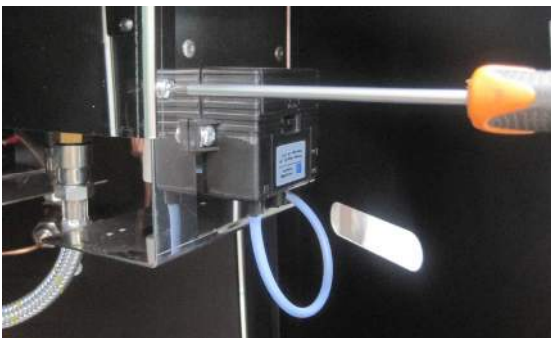

Picture 14

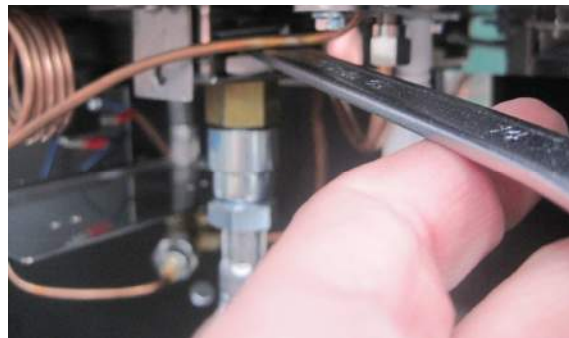

Picture 15

**Patio-heater KALOR-SOLEIL:** to replace the gas nozzle remove one of the protection grids, remove the perforated screen and unscrew the brass gas nozzle with M13 key (Picture 16). Mount the new nozzle and tighten with the spanner, position the perforated screen and the protection grid.



Picture 16

## Trouble shooting

### *Patio-heaters KALIENTE M-SOLFLAME M, MANUAL version*

<b>Trouble</b>	<b>Possible cause</b>	<b>Solution</b>
<b>A Pilot on, main burner not</b>	<b>A1</b> Fault with gas tap	<b>A1</b> Replace gas tap
<b>B Continues to sparkle, the pilot does not light</b>	<b>B1</b> Lack of gas <b>B2</b> Blockage of pilot group <b>B3</b> Fault with thermocouple <b>B4</b> Anti tilt sensor locked	<b>B1</b> Check opening of gas valve, placed on gas bottle, check the gas reducer <b>B2</b> Blow with air at low pressure the pilot group <b>B3</b> Replace thermocouple <b>B4</b> Replace anti tilt sensor
<b>C The pilot turns on, then it turns off as soon as you release the gas tap</b>	<b>C1</b> Fault with thermocouple	<b>C1</b> Replace thermocouple
<b>D No spark at pilot start-up</b>	<b>D1</b> Spark electrode damaged <b>D2</b> Spark cable is not connected	<b>D1</b> Replace electrode <b>D2</b> Reconnect with faston the spark cable
<b>E Lack of flame</b>	<b>E1</b> Bad LPG gasification <b>E2</b> Thermocouple broken <b>E3</b> Gas circuit blocked <b>E4</b> Leaks in gas circuit <b>E5</b> Battery of start down <b>E6</b> Replace pressure regulator	<b>E1</b> Replace gas bottle <b>E2</b> Replace thermocouple <b>E3</b> Clean gas circuit <b>E4</b> Fix possible leak <b>E5</b> Replace battery <b>E6</b> Replace regulator
<b>F Darkening of glass tube</b>	<b>F1</b> Poor quality of gas <b>F2</b> Poor draft <b>F3</b> Dirty burner	<b>F1</b> Replace gas bottle, with better quality gas <b>F2</b> Check presence of wind <b>F3</b> Blow burner with air at low pressure

## Trouble shooting

### *Patio-heaters KALIENTE E/SOLFLAME E, ELECTRONIC version*

<b>Trouble</b>	<b>Possible cause</b>	<b>Solution</b>
<b>A Pilot on, spark continuously running</b>	<b>A1</b> Spark sensor not connected <b>A2</b> Fault with spark electrode <b>A3</b> Fault with command control	<b>A1</b> Check spark cable connection <b>A2</b> Replace electrode <b>A3</b> Replace control
<b>B Pilot flame on, and main burner off</b>	<b>B1</b> Burner nozzle blocked <b>B2</b> Fault with gas valve <b>B3</b> Fault with remote control <b>B4</b> Fault with cables	<b>B1</b> Check nozzle and clean <b>B2</b> Replace gas group <b>B3</b> Replace remote control <b>B4</b> Check cables connection
<b>C Unable to set the intensity of the flame, or work partially</b>	<b>C1</b> Fault with cables <b>C2</b> Fault with remote control <b>C3</b> Fault with command control	<b>C1</b> Replace thermocouple <b>C2</b> Replace remote control <b>C3</b> Replace command control
<b>D No spark at pilot start-up</b>	<b>D1</b> Fault with spark electrode <b>D2</b> Spark sensor not connected <b>D3</b> Fault with command control	<b>D1</b> Replace electrode <b>D2</b> Reconnect with faston the spark cable <b>D3</b> Replace command control
<b>E Lack of flame</b>	<b>E1</b> Bad LPG gasification <b>E2</b> Thermocouple broken <b>E3</b> Gas circuit blocked <b>E4</b> Leaks in gas circuit <b>E5</b> Battery of start down <b>E6</b> Replace pressure regulator	<b>E1</b> Replace gas bottle <b>E2</b> Replace thermocouple <b>E3</b> Clean gas circuit <b>E4</b> Fix possible leak <b>E5</b> Replace battery <b>E6</b> Replace regulator
<b>F Darkening of glass tube</b>	<b>F1</b> Poor quality of gas <b>F2</b> Poor draft <b>F3</b> Dirty burner	<b>F1</b> Replace gas bottle, with better quality gas <b>F2</b> Check presence of wind <b>F3</b> Blow burner with air at low pressure

## Trouble shooting

### *Patio-heaters KALOR M/SOLEIL M, MANUAL version*

<b>Trouble</b>	<b>Possible cause</b>	<b>Solution</b>
<b>A Continues to sparkle, the burner does not start</b>	<b>A1</b> Lack of gas <b>A2</b> Gas valve blocked <b>A3</b> Fault with thermocouple <b>A4</b> Anti tilt sensor blocked	<b>A1</b> Check opening of gas valve, placed on gas bottle, check the gas reducer <b>A2</b> Blow with air at low pressure the valve group <b>A3</b> Replace thermocouple <b>A4</b> Replace anti tilt sensor
<b>B The burner turns on, then it turns off as soon as you release the tap version</b>	<b>B1</b> Fault with thermocouple	<b>B1</b> Replace thermocouple
<b>C No spark at burner ignition</b>	<b>C1</b> Spark electrode damaged <b>C2</b> Spark cable not connected	<b>C1</b> Replace spark electrode <b>C2</b> Reconnect with faston the spark cable
<b>D Lack of flame</b>	<b>D1</b> Bad LPG gasification <b>D2</b> Thermocouple broken <b>D3</b> Gas circuit blocked <b>D4</b> Leaks in gas circuit <b>D5</b> Battery of start down <b>D6</b> Replace pressure regulator	<b>D1</b> Replace gas bottle <b>D2</b> Replace thermocouple <b>D3</b> Clean gas circuit <b>D4</b> Fix possible leak <b>D5</b> Replace battery <b>D6</b> Replace regulator

## List of suggested spare-parts

### ***SPARE-PARTS list***

<b>Description</b>	<b>Code</b>	<b>Quantity</b>
. anti-tilt sensor	FD4SWITCK	_____
. pressure regulator	RG13.855800	_____
. gas conversion kit (nozzle + technical plate)	various	_____
<b>Patio-heater KALIENTE/SOLFLAME ELECTRONIC</b>		
. glass pipe	001TOBF1200	_____
. pilot, complete	440.1221.13	_____
. electrodes set	031.0014.00	_____
. ignition group	0102EKAL12	_____
. cables DC	0104EKAL12	_____
. battery box	0105EKAL12	_____
. remote control	0103EKAL12	_____
<b>Patio-heater KALIENTE/SOLFLAME MANUAL</b>		
. glass pipe	001TOBF1200	_____
. pilot, complete	440.1221.13	_____
. electrodes set	031.0014.00	_____
. thermo-couple	2552000023	_____
. battery starter	0073801	_____
. start-up button	202623	_____
. black knob	3001	_____
<b>Patio-heater KALOR/SOLEIL MANUAL</b>		
. gas tap	7989B-1	_____
. electrodes set	08213411	_____
. thermo-couple	2552000023	_____
. battery starter	0073801	_____
. start-up button	202623	_____
. black knob	3001	_____

**N.B. – at order specify model, gas type and serial number**



## CE certificate



Numero / Number KIP-076123/02 Sostituisce / Replaces KIP-076123/01  
Emesso / Issued 09/04/2014 Scopo / Scope Directive 2009/142/EC  
Rapporto / Report 120700008  
PIN 0694CN6054

### CERTIFICATO DI ESAME CE DI TIPO EC TYPE EXAMINATION CERTIFICATE

**Kiwa dichiara che i prodotti**  
*Kiwa hereby declares that the products*

**diffusori radianti per uso esterno, tipo**  
*patio heaters for outdoor use, type*

Marchio / trade mark: **SIABS**

Modelli / models:	KALOR E	SOLEIL E
	KALOR M	SOLEIL M
	KALIENTE E	SOLFLAME E
	KALIENTE M	SOLFLAME M

costruiti da /

*made by* **SIABS S.r.l.**  
*di / in* Casorezzo (MI), Italia

soddisfano i requisiti riportati nella  
*meets the essential requirements as described in the*  
**Direttiva Apparecchi a Gas 2009/142/CE**  
*Directive on appliances burning gaseous fuels 2009/142/EC*

I suddetti prodotti sono stati approvati per  
*Mentioned products have been approved for*

Tipi di apparecchi / *appliance type* : A<sub>1</sub>

Paesi e categorie apparecchi / *Countries and appliance categories*  
AL, AT, BE, BG, CH, CY, CZ, DE, DK, EE, ES, FI, FR, GB, GR, HR, HU, IE,  
IS, IT, LT, LU, LV, MK, MT, NO, NL, PL, PT, RO, SE, SI, SK, TR

I <sub>2H</sub>	G20	20 mbar	
I <sub>2H</sub>	G20	25 mbar	(HU only)
I <sub>2E</sub>	G20	20 mbar	
I <sub>2E+</sub>	G20/G25	20/25 mbar	
I <sub>2L</sub>	G25	25 mbar	(NL only)
I <sub>3+</sub>	G30/G31	28-30/37 mbar	
I <sub>3P</sub>	G31	37 mbar	
I <sub>3P</sub>	G31	50 mbar	
I <sub>3B</sub>	G30	30 mbar	
I <sub>3B-P</sub>	G30	30 mbar	
I <sub>3B-P</sub>	G30	50 mbar	

Le famiglie di gas e gruppi di gas sopra indicati possono essere combinati per ottenere le categorie II e III secondo la norma EN437: 2009 in accordo alla legislazione nazionale dei paesi.  
*The above gas families and gas groups can be combined to obtain categories II and III according to the standard EN437:2009 and national situation of countries.*

Kiwa Italia S.p.a.

*Sede Legale:*  
Via C. Goldoni, 1  
20129 Milano

*Sede Amministrativa e operativa:*  
Via Treviso, 32/34  
31020 San Vendemiano (TV)

[www.kiwa.com](http://www.kiwa.com)

**GASTEC**

Kiwa

Ing. Emanuele Ferrari  
Director Product Certification

**kiwa**  
Approved

EC Directive

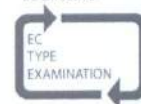

2009/142/EC  
92/42/EEC

**GASTEC**

**CE**  
**0694**

## Service sheet

**DATE and STAMP**

**OPERATION / NOTE**

---

---

---

---

---

**DATE and STAMP**

**OPERATION / NOTE**

---

---

---

---

---

**DATE and STAMP**

**OPERATION / NOTE**

---

---

---

---

---

**DATE and STAMP**

**OPERATION / NOTE**

---

---

---

---

---

## Decommissioning and disposal

**INFORMATION TO USERS** "Implementation of Directives 2002/95/EC, 2002/96/EC and 2003/108/EC, relating to the use of hazardous substances in electrical and electronic equipment, as well as waste disposal"

The product at the end of its useful life **must be separated from other waste**. You should therefore **give the equipment at end of its working life to appropriate separate collection centres of electric and electronic waste**, or return it to the dealer when purchasing a new device to be equivalent in terms of one to one.

The proper differentiated collection to deliver the decommissioned apparatus to recycling, treatment and environmentally compatible disposal, helps to avoid possible negative effects on environmental and health, and promote the recycling of materials making up the equipment.

Illegal disposal of the product by the holder imply the application of administrative penalties according to law.



**N.B. – Do not dispose the product in mixed waste**

**SIABS S.r.l.**  
**via Del Lavoro, 7**  
**20010 – Casorezzo (MI)**  
**ITALIA**

---

To contact us:

Phone           +39 02 90384081  
Fax              +39 02 9029538  
E-mail          [commerciale@siabs.it](mailto:commerciale@siabs.it)  
Web page       [www.siabs.com](http://www.siabs.com)

Continuous development to improve the product could cause changes of above without notice.